

ENGINE

John Deere engineered and manufactured 7.6 liter diesel engine features a high-efficiency turbo-charger for maximum performance. Replaceable wet-type cylinder liners help ensure superior heat dissipation, longer engine life. High-strength alloy cylinder heads include replaceable valve seat inserts. Cast aluminum pistons reduce rod bearing loads and provide vital heat transfer; pistons are sprayed with cooling oil for longer engine life.

Engine: John Deere 6076T

Rated power at 2200 rpm.....	165 net hp (123 kW)
	173 gross hp (129 kW)
Turbocharger	standard
Cylinders	6
Displacement	466 cu. in. (7.638 L)
Fuel consumption, typical	3.4 to 5.0 gal./hr. (12.9 to 18.9 L/h)
Max. net torque rise	
35% at 1350 rpm	532 lb.-ft. (721 Nm)
Lubrication	pressure system with full-flow filter
Electrical system	12 volt with 78-amp alternator
Battery	reserve capacity 180 minutes

TRANSMISSION

The direct-drive power shift transmission is engineered and manufactured by John Deere specifically for skidders. Eight speeds in forward, four speeds in reverse. The transmission charge pump is externally mounted for easy servicing.

TRAVEL SPEEDS

At 2200 engine rpm, no tire slip, with 24.5-32 tires

	mph	(km/h)
Forward	1.6-18.0	2.6-29.0
Reverse.....	2.3-6.5	3.7-10.4

AXLES

Heavy-duty, inboard-mounted planetary-type final drives distribute shock loads evenly. Hydraulically-applied differential lock is standard equipment in both front and rear axles. Differential can either be locked for exceptional traction, or unlocked for easy maneuvering with less tire wear.

BRAKES

Hydraulic, annular-style wet-disk brakes are mounted inboard on both axles as standard equipment. Completely sealed and running in a cooling oil bath, they are self-adjusting, self-equalizing and need no periodic service. A spring-applied, hydraulically-released wet multi-disk parking brake is mounted on the transmission, and is automatically applied when the engine is off. This brake can be manually applied by placing the transmission control lever in the *park* position.

STEERING

The load- and speed-sensing power steering system delivers quick response and power for easy maneuvering in the woods. Its 90 degrees of frame articulation (45 degrees each direction) provide exceptional maneuverability.

Outside clearance circle with blade42 ft. 0 in. (12.8 m)

HYDRAULICS

The quick, responsive and powerful hydraulic system features an axial-piston, pressure-compensated pump and closed-center design. The hydraulic system is separate from the transmission, enhancing the overall reliability of both systems.

Pump flow at 2200 rpm.....27 gpm (102 L/min)
3000 psi (20 684 kPa)

TIRES

24.5-32, 12 PR LS2	30.5-32, 12 PR LS2
24.5-32, 16 PR LS2	30.5-32, 16 PR LS2

CABLE ARCH

Horizontal roller8 in. (203 mm) diameter
Vertical rollers
(through hardened steel)4.5 in. (114 mm) diameter

WINCH

The John Deere-engineered and manufactured direct-drive 6000 Winch includes wet multi-disk clutch and spring-applied, hydraulically-released brake. The adjustable free-spool feature and low-friction drum seals increase ease of operation. All winch functions are controlled by a single conveniently-located lever.

Cable capacity – calculated – no allowance made for loose or uneven spooling

.625 in. (15.8 mm) cable.....	373 ft. (114 m)
.75 in. (19.1 mm) cable.....	263 ft. (80.2 m)
.875 in. (22.2 mm) cable.....	189 ft. (58 m)
1 in. (25.4 mm) cable.....	147 ft. (45 m)

Linepull at peak engine and .75 in. (19 mm) cable
Bare drum46,861 lb. (208 kN)
Full drum29,763 lb. (132 kN)

Line speed at 2200 rpm and .75 in. (19 mm) cable
Bare drum145 fpm (44.2 m/min.)
Full drum228 fpm (69.5 m/min.)

CAPACITIES

	U.S.	
Fuel tank.....	62 gal.	(234.7 L)
Cooling system.....	30 qt.	(28.4 L)
Engine lubrication, including filter	25 qt.	(23.7 L)
Transmission.....	7.75 gal.	(29.3 L)
Front differential	7.5 gal.	(28.4 L)
Rear differential	7.5 gal.	(28.4 L)
Winch, 6000	12 gal.	(45.4 L)
Hydraulic reservoir capacity.....	11 gal.	(41.6 L)

OPERATING WEIGHT

740E with standard equipment.....28,600 lb. (12 973 kg)

DIMENSIONS

Sideview dimensions are for skidder equipped with 24.5-32, 12 PR LS2 tires and adjustable log arch.

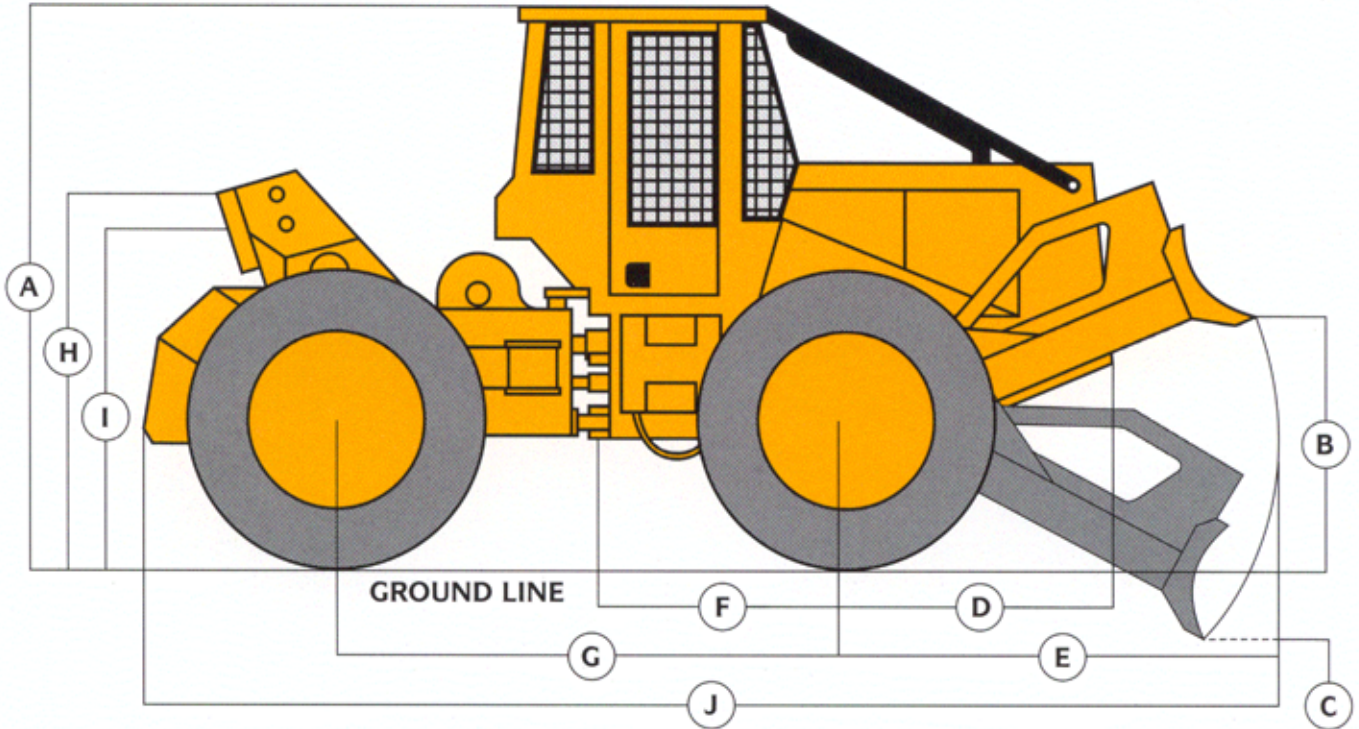

Key:

A Overall height	10 ft. 2.5 in. (3.11 m)
B Maximum blade lift above ground	4 ft. 10.3 in. (1.48 m)
C Maximum blade dig below ground	14.8 in. (376 mm)
D Front axle to front of machine	70 in. (1778 mm)
E Front axle to blade cutting edge arc	97.4 in. (2474 mm)
F Front axle to articulation joint	68 in. (1727 mm)
G Wheelbase	145 in. (3683 mm)
H Main fairlead roller height (top)	8 ft. 9 in. (2.67 m)
I Auxiliary position fairlead roller height (middle)	8 ft. 1.8 in. (2.48 m)
	(lower).....
J Overall length	7 ft. 6.5 in. (2.30 m)
	24 ft. 0 in. (7.32 m)

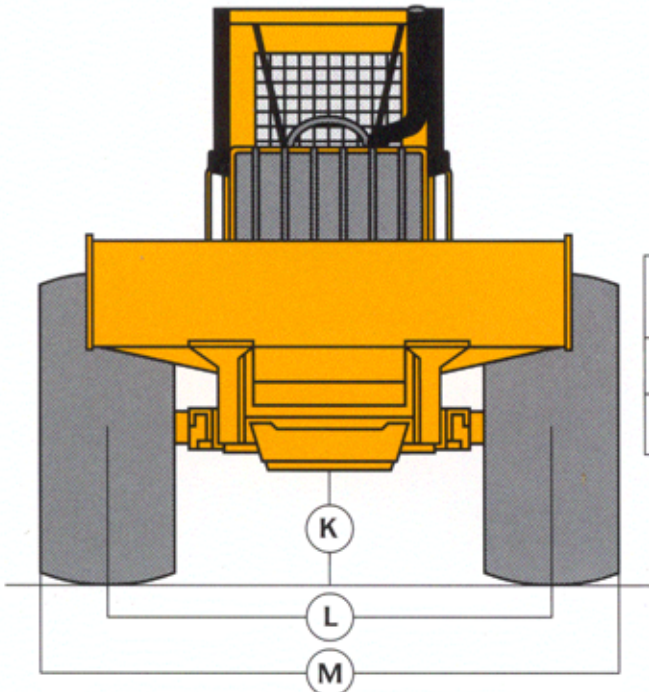

Tire Size	K Ground Clearance	L Wheel Tread	M Overall Width
24.5-32	22.9 in. (582 mm)	8 ft. 3 in. (2.49 m)	10 ft. 2.5 in. (3.11 m)
30.5-32	23.6 in. (599 mm)	8 ft. 2 in. (2.46 m)	10 ft. 7.5 in. (3.24 m)