

444 **G**

Wheel Loader



JOHN DEERE



444 G-TIER WHEEL LOADER



DEPENDABLE, ECONOMICAL, AND READY TO WORK

When you need a multipurpose wheel loader you can count on, look to the John Deere 444 G-Tier. Ideal for everything from dirt work, to truck loading, to snow removal, this mid-size machine provides a rugged and reliable solution at an economical price point. Featuring quality components and reliable systems backed by legendary Deere dealer support, the 444 G-Tier can be just what you need to get things done.



FEATURES

Versatility to the max

Equip your John Deere 444 G-Tier Loader with a Hi-Vis/ISO- or JRB-style coupler, which accepts L- and K-Series as well as G-, P-, and X-Tier buckets and other attachments, to maximize machine utilization and versatility.

Operator experience

Comfortable and spacious cab features ergonomically placed joystick controls, foot pedals, sealed-switch module (SSM), and adjustable five-inch monitor that displays vital machine data as well as the view from the rearview camera.* Common controls will be familiar to both novice and skilled operators. In-cab adjustable boom-height kickout, return to carry, and return to dig can be easily activated from the SSM, boosting productivity in repetitive applications.

Smooth moves

Optional ride control cushions boom movements to enhance the overall ride and reduce material spillage.

Reach for more

For extra reach when loading trucks, hoppers, or feed mixers, adding High-Lift linkage provides an extra 17 inches of hinge-pin height over standard linkage.

Let it snow

Contractors and governmental agencies can specifically benefit from using the 444 G-Tier Loader for snow-removal tasks. Snow tires, couplers, beacons, and third-function hydraulics are available from the factory to equip your machine to handle the white stuff.

*Rearview camera standard for EPA Final Tier 4/ EU Stage V; optional for EPA Tier 3/EU Stage IIIA.

 + 
RELIABLE **SIMPLE TO SERVICE**

FIND YOUR FIT



LEADING EDGE

Premium edge with innovative technology



EXCEPTIONAL PERFORMANCE

Advanced features and performance



RUGGED AND RELIABLE

Proven capabilities and value

Proven to go the distance

Powered by the reliable John Deere 4.5L engine found in our 444 P-Tier Loader, the 444 G-Tier uses components similar to those featured in both our current and previous series loaders for decades. Rugged powertrain with newly updated transmission, limited slip differentials, and hydraulic and electrical systems are the result of thousands of hours of experience on a wide range of jobsites. Auto-idle and auto shut-down reduce engine speed or turn it off after a period of inactivity to save fuel and warranty hours.

Practical performer

The John Deere 444 G-Tier Wheel Loader was designed to deliver a low-cost solution while providing the type of performance you're accustomed to with the 444 P-Tier model.

Debris clearing

Optional debris package including centrifugal air precleaner and auto reversing fan enables clean air to enter the engine and cooling system to efficiently clear damaging clogs.

Service and support you can count on

Renowned John Deere and dealer support, parts availability, and warranty help keep your equipment up and running. All daily service points including fuel refill are conveniently grouped at ground level on the left side of the machine. Sight gauges for transmission and hydraulic fluid levels are easy to read. Hinged doors provide wide-open access to the engine, cooling system, and other components.



444 G-TIER WHEEL LOADER



Connected machines

John Deere construction equipment comes with in-base connectivity — free from subscriptions or annual renewals. Analyze critical machine data, track utilization, review diagnostic alerts, and more from **the John Deere Operations Center™**. The Operations Center also enables **John Deere Connected Support™**, which uses data from thousands of connected machines to proactively address issues before they arise. Your dealer can also remotely monitor machine health, diagnose problems, and even update machine software without a trip to the jobsite.*

*Availability varies by region and product. Options not available in every country.



444 G-TIER WHEEL LOADER SPECIFICATIONS

While general information, pictures, and descriptions are provided, some illustrations and text may include product options and accessories NOT AVAILABLE in all regions, and in some countries products and accessories may require modifications or additions to ensure compliance with the local regulations of those countries.

| Engine | 444 G Z-BAR / HIGH-LIFT TIER 3 | | 444 G Z-BAR / HIGH-LIFT FINAL TIER 4 (FT4) | |
|---|--|----------------------|---|----------------------|
| Manufacturer and Model | John Deere PowerTech™ E 4045H | | John Deere PowerTech™ PSS 4045 | |
| Non-Road Emission Standard | EPA Tier 3/EU Stage IIIA | | EPA FT4/EU Stage V | |
| Cylinders | 4 | | 4 | |
| Valves Per Cylinder | 2 | | 4 | |
| Displacement | 4.5 L (276 cu. in.) | | 4.5 L (276 cu. in.) | |
| Net Peak Power (ISO 9249) | 92 kW (124 hp) at 2,100 rpm / 88 kW (118 hp) at 2,100 rpm* | | 92 kW (124 hp) at 2,100 rpm | |
| Gross Peak Power (ISO 9249) | 97 kW (130 hp) at 2,100 rpm | | 103 kW (138 hp) at 1,800 rpm | |
| Net Peak Torque (ISO 9249) | 507 Nm (374 lb.-ft.) at 1,500 rpm / 504 Nm (372 lb.-ft.) at 1,500 rpm* | | 532 Nm (392 lb.-ft.) at 1,400 rpm | |
| Gross Peak Torque (ISO 9249) | 525 Nm (387 lb.-ft.) at 1,600 rpm | | 550 Nm (405 lb.-ft.) at 1,400 rpm | |
| Net Torque Rise | 26% | | 34% | |
| Fuel System (electronically controlled) | High-pressure common rail | | High-pressure common rail | |
| Lubrication | Full-flow spin-on filter and integral cooler | | Full-flow spin-on filter and integral cooler | |
| Aspiration | Turbocharged, charge air cooled | | Turbocharged, charge air cooled | |
| Air Cleaner | Under-hood, dual-element dry type, restriction indicator in cab monitor for service | | | |
| *With fix-fan drive. | | | | |
| Cooling | Fix-fan drive standard / hydraulically driven, proportionally controlled optional | | Hydraulically driven, proportionally controlled | |
| Electrical | 24 volt with 80-amp alternator | | 24 volt with 100-amp alternator | |
| Batteries (2 – 12 volt) | 750 CCA (each) | | 950 CCA (each) | |
| Transmission System | Countershaft-type PowerShift™ | | Countershaft-type PowerShift | |
| Torque Converter | Single stage, single phase | | Single stage, single phase | |
| Shift Control | Electronically modulated, adaptive, load and speed dependent | | Electronically modulated, adaptive, load and speed dependent | |
| Operator Interface | Steering-column or joystick-mounted F-N-R and gear-select lever; kick-down button on hydraulic lever | | Joystick-mounted F-N-R and gear-select lever; kick-down button on hydraulic lever | |
| Shift Modes | Manual/auto (1st–D or 2nd–D); Quick-Shift button with 2 cutoff settings | | 2 selectable modes: kick-down or kick-up/down; and 4 clutch | |
| | <i>Standard 4-Speed</i> | | <i>Standard 4-Speed</i> | |
| Maximum Travel Speeds (with 17.5 R 25 tires) | <i>Forward</i> | <i>Reverse</i> | <i>Forward</i> | <i>Reverse</i> |
| Range 1 | 7.3 km/h (4.5 mph) | 7.6 km/h (4.7 mph) | 7.3 km/h (4.5 mph) | 7.6 km/h (4.7 mph) |
| Range 2 | 12.1 km/h (7.5 mph) | 13.0 km/h (8.1 mph) | 12.1 km/h (7.5 mph) | 13.0 km/h (8.1 mph) |
| Range 3 | 23.1 km/h (14.4 mph) | 24.2 km/h (15.0 mph) | 23.1 km/h (14.4 mph) | 24.2 km/h (15.0 mph) |
| Range 4 | 36.0 km/h (22.4 mph) | N/A | 36.0 km/h (22.4 mph) | N/A |
| Axles/Brakes | 444 G Z-BAR / HIGH-LIFT TIER 3 / FT4 | | | |
| Final Drives | Heavy-duty mid-board planetary | | | |
| Differentials | Limited slip | | | |
| Rear Axle Oscillation, Stop to Stop (with 17.5 R 25 tires) | 24 deg. (12 deg. each direction) | | | |
| Brakes (conform to ISO 3450) | Outboard, forced oil cooled, multi disc | | | |
| Service | Automatic spring applied, hydraulically released, driveline mounted, sealed wet multi disc | | | |
| Parking | Automatic spring applied, hydraulically released, driveline mounted, sealed wet multi disc | | | |
| 444 G Z-BAR / HIGH-LIFT TIER 3 Tires/Wheels (see page 10 for complete tire adjustments) | <i>Tread Width</i> | | <i>Width Over Tires</i> | |
| Michelin 17.5 R 25, 1 Star L-3 | 1900 mm (74.8 in.) | | 2415 mm (95.1 in.) | |
| 444 G Z-BAR / HIGH-LIFT FT4 Tires/Wheels (see page 10 for complete tire adjustments) | <i>Tread Width</i> | | <i>Width Over Tires</i> | |
| Michelin 20.5 R 25 L2 1-Star | 1950 mm (74.8 in.) | | 2415 mm (95.1 in.) | |
| Serviceability | 444 G Z-BAR / HIGH-LIFT TIER 3 | | 444 G Z-BAR / HIGH-LIFT FT4 | |
| Refill Capacities | 444 G Z-BAR / HIGH-LIFT TIER 3 | | 444 G Z-BAR / HIGH-LIFT FT4 | |
| Fuel Tank (with lockable cap) | 190 L (50 gal.) | | 190 L (50 gal.) | |
| Diesel Exhaust Fluid (DEF) | N/A | | 15.6 L (16.5 qt.) | |
| Cooling System | 19 L (20 qt.) | | 19 L (20 qt.) | |
| Engine Oil With Vertical Spin-On Filter | 17.5 L (18.5 qt.) | | 14.5 L (15.3 qt.) | |
| Transmission Reservoir With Vertical Filter | 18.5 L (19.5 gal.) | | 18.5 L (19.5 gal.) | |
| Axle Oil Without Coolers (front and rear, each) | 22 L (23 qt.) | | 22 L (23 qt.) | |
| Hydraulic Reservoir and Filter | 92 L (24.3 gal.) | | 92 L (24.3 gal.) | |
| Park Brake Oil (wet disc) | 0.35 L (12 oz.) | | 0.35 L (12 oz.) | |

444 G-TIER WHEEL LOADER SPECIFICATIONS

444

G

While general information, pictures, and descriptions are provided, some illustrations and text may include product options and accessories NOT AVAILABLE in all regions, and in some countries products and accessories may require modifications or additions to ensure compliance with the local regulations of those countries.

| Hydraulic System/Steering | | 444 G Z-BAR / HIGH-LIFT TIER 3 / FT4 |
|--|--|--------------------------------------|
| Pump (loader and steering) | Variable-displacement, axial-piston pump; closed-center, pressure-compensating system | |
| Maximum Rated Flow at 6895 kPa (1,000 psi) and 2,350 rpm | 140 L/m (37 gpm) | |
| System Relief Pressure (loader and steering) | 24 821 kPa (3,600 psi) | |
| Loader Controls | 2-function valve; joystick control; hydraulic-function enable/disable; optional 3rd- and 4th-function valve with auxiliary lever | |
| Steering (conforms to ISO 5010) | | |
| Type | Power, fully hydraulic | |
| Articulation Angle | 80-deg. arc (40 deg. each direction) | |
| Turning Radius (measured to centerline of outside tire) | 4.74 m (15 ft. 7 in.) | |
| Hydraulic Cycle Times | | |
| Raise | 5.9 sec. | |
| Dump | 1.0 sec. | |
| Lower (float down) | 2.4 sec. | |
| Total | 9.3 sec. | |

Dimensions and Specifications With Pin-On Bucket

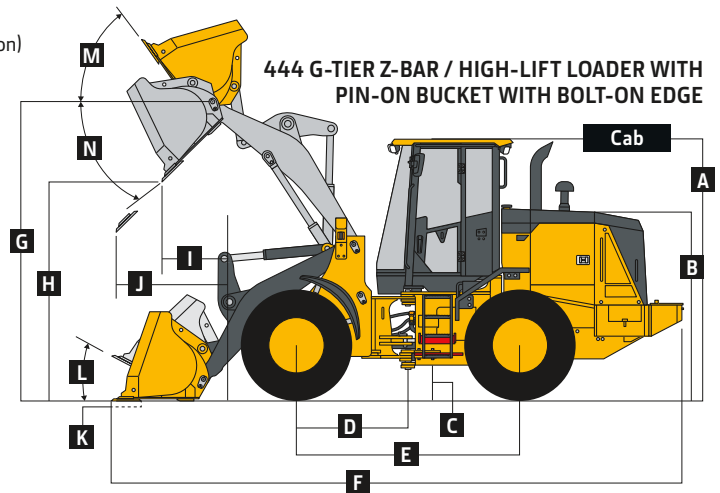

| Key: General-Purpose (GP) | Tier 3 | Tier 3 | FT4 | FT4 |
|---|-------------------------------------|-------------------------------------|-------------------------------------|-------------------------------------|
| | Z-Bar | Z-Bar (with concrete counterweight) | Z-Bar | Z-Bar / High-Lift |
| Dimensions With Bucket With Bolt-On Edge | 1.9-m ³ (2.5 cu. yd.) GP | 1.9-m ³ (2.5 cu. yd.) GP | 1.9-m ³ (2.5 cu. yd.) GP | 1.9-m ³ (2.5 cu. yd.) GP |
| A Height to Top of Cab | 3.13 m (10 ft. 3 in.) | 3.13 m (10 ft. 3 in.) | 3.21 m (10 ft. 7 in.) | 3.21 m (10 ft. 7 in.) |
| B Hood Height | 2.26 m (7 ft. 5 in.) | 2.26 m (7 ft. 5 in.) | 2.38 m (7 ft. 10 in.) | 2.38 m (7 ft. 10 in.) |
| C Ground Clearance | 349 mm (13.75 in.) | 349 mm (13.75 in.) | 430 mm (17 in.) | 430 mm (17 in.) |
| D Length From Centerline to Front Axle | 1.37 m (4 ft. 6 in.) | 1.37 m (4 ft. 6 in.) | 1.37 m (4 ft. 6 in.) | 1.37 m (4 ft. 6 in.) |
| E Wheelbase | 2.76 m (9 ft. 6 in.) | 2.76 m (9 ft. 6 in.) | 2.76 m (9 ft. 6 in.) | 2.76 m (9 ft. 6 in.) |
| F Overall Length, Bucket on Ground | 6.75 m (22 ft. 2 in.) | 6.93 m (22 ft. 9 in.) | 7.01 m (23 ft. 0 in.) | 7.45 m (24 ft. 6 in.) |
| G Height to Hinge Pin, Fully Raised | 3.58 m (11 ft. 9 in.) | 3.58 m (11 ft. 9 in.) | 3.66 m (12 ft. 1 in.) | 4.11 m (13 ft. 6 in.) |
| H Dump Clearance, 45 deg., Full Height | 2.65 m (8 ft. 8 in.) | 2.65 m (8 ft. 8 in.) | 2.73 m (9 ft. 0 in.) | 3.21 m (10 ft. 7 in.) |
| I Reach, 45-deg. Dump, Full Height | 1.05 m (3 ft. 5 in.) | 1.05 m (3 ft. 5 in.) | 0.98 m (3 ft. 3 in.) | 1.03 m (3 ft. 5 in.) |
| J Reach, 45-deg. Dump, 2.13-m (7 ft. 0 in.) Clearance | 1.44 m (4 ft. 9 in.) | 1.44 m (4 ft. 9 in.) | 1.41 m (4 ft. 8 in.) | 1.8 m (5 ft. 11 in.) |
| K Maximum Digging Depth | 143 mm (5.6 in.) | 143 mm (5.6 in.) | 80 mm (3.14 in.) | 90 mm (3.54 in.) |
| L Maximum Rollback at Ground Level | 41 deg. | 41 deg. | 41 deg. | 40 deg. |
| M Maximum Rollback, Boom Fully Raised | 55 deg. | 55 deg. | 55 deg. | 49 deg. |
| N Maximum Bucket Dump Angle, Fully Raised | 50 deg. | 50 deg. | 50 deg. | 44 deg. |
| Loader Clearance Circle, Bucket Carry Position | 11.11 m (36 ft. 5 in.) | 11.11 m (36 ft. 5 in.) | 11.07 m (36 ft. 4 in.) | 11.44 m (37 ft. 7 in.) |
| Specifications With Bucket With Bolt-On Edge | | | | |
| Capacity, Heaped | 1.9 m ³ (2.5 cu. yd.) | 1.9 m ³ (2.5 cu. yd.) | 1.9 m ³ (2.5 cu. yd.) | 1.9 m ³ (2.5 cu. yd.) |
| Capacity, Struck | 1.6 m ³ (2.0 cu. yd.) | 1.6 m ³ (2.0 cu. yd.) | 1.6 m ³ (2.0 cu. yd.) | 1.6 m ³ (2.0 cu. yd.) |
| Bucket Width | 2.52 m (8 ft. 4 in.) | 2.52 m (8 ft. 4 in.) | 2.52 m (8 ft. 4 in.) | 2.52 m (8 ft. 4 in.) |
| Breakout Force | 8000 kg (17,637 lb.) | 8000 kg (17,637 lb.) | 8004 kg (17,645 lb.) | 7259 kg (16,003 lb.) |
| Tipping Load, Straight, No Tire Deflection | 7556 kg (16,637 lb.) | 9539 kg (21,006 lb.) | 9660 kg (21,296 lb.) | 7852 kg (17,310 lb.) |
| Tipping Load, Straight, With Tire Deflection | 7161 kg (15,768 lb.) | 9009 kg (19,838 lb.) | 9183 kg (20,245 lb.) | 7515 kg (16,567 lb.) |
| Tipping Load, 40-deg. Full Turn, No Tire Deflection | 6606 kg (14,546 lb.) | 8267 kg (18,205 lb.) | 8396 kg (18,509 lb.) | 6796 kg (14,982 lb.) |
| Tipping Load, 40-deg. Full Turn, With Tire Deflection | 6120 kg (13,476 lb.) | 7614 kg (16,766 lb.) | 7812 kg (17,222 lb.) | 6369 kg (14,041 lb.) |
| Rated Operating Load, 50% Full-Turn Tipping Load, No Tire Deflection (conforms to ISO 14397-1)* | 3303 kg (7,273 lb.) | 4134 kg (9,102 lb.) | 4198 kg (9,254 lb.) | 3398 kg (7,491 lb.) |
| Rated Operating Load, 50% Full-Turn Tipping Load, With Tire Deflection (conforms to ISO 14397-1)* | 3060 kg (6,738 lb.) | 3807 kg (8,383 lb.) | 3906 kg (8,611 lb.) | 3184 kg (7,020 lb.) |
| Operating Weight | 10 026 kg (22,077 lb.) | 10 880 kg (23,958 lb.) | 11 289 kg (24,887 lb.) | 11 471 kg (25,289 lb.) |

Loader operating information is based on machine with identified linkage and standard equipment, John Deere PowerTech E 4045H/PowerTech PSS 4045 engine, ROPS cab, transmission side-frame guards, standard tires (175 R25 for Tier 3/20.5 R25 for FT4), full fuel tank, and 79-kg (175 lb.) operator. This information is affected by changes in tires, ballast, and different attachments.

*Rated operating capacity based on Deere attachments only.

444 G-TIER

While general information, pictures, and descriptions are provided, some illustrations and text may include product options and accessories NOT AVAILABLE in all regions, and in some countries products and accessories may require modifications or additions to ensure compliance with the local regulations of those countries.

Dimensions and Specifications With Hi-Vis Coupler and Hook-On Bucket **444 G Z-BAR / HIGH-LIFT TIER 3 / FINAL TIER 4 (FT4)**

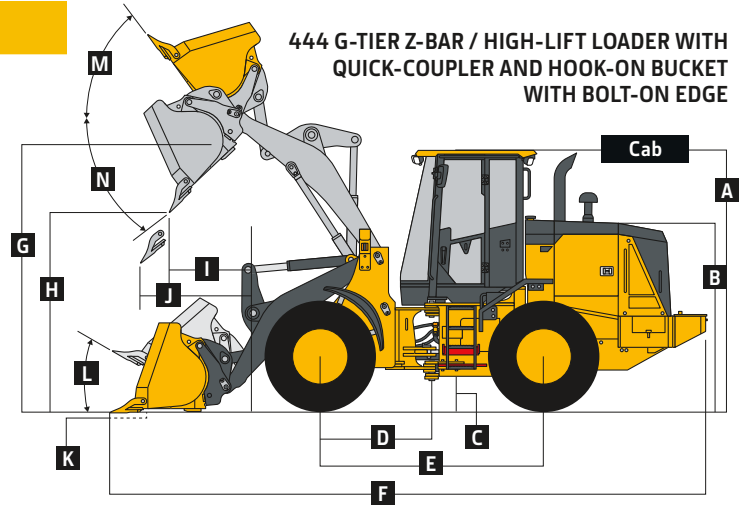

444 G-TIER Z-BAR / HIGH-LIFT LOADER WITH QUICK-COUPLER AND HOOK-ON BUCKET WITH BOLT-ON EDGE

| Key: General-Purpose (GP) | Tier 3 | Tier 3 Z-Bar (with concrete counterweight) | FT4 | FT4 | FT4 | FT4 |
|--|---|---|---|--|---|--|
| Dimensions With Bucket With Bolt-On Edge | Z-Bar 1.9-m ³ (2.5 cu. yd.) GP | Z-Bar (with concrete counterweight) 1.9-m ³ (2.5 cu. yd.) GP | Z-Bar 1.9-m ³ (2.5 cu. yd.) GP | Z-Bar 2.1-m ³ (2.75 cu. yd.) GP | Z-Bar / High-Lift 1.9-m ³ (2.5 cu. yd.) GP | Z-Bar / High-Lift 2.1-m ³ (2.75 cu. yd.) GP |
| A Height to Top of Cab | 3.13 m (10 ft. 3 in.) | 3.13 m (10 ft. 3 in.) | 3.21 m (10 ft. 7 in.) | 3.21 m (10 ft. 7 in.) | 3.21 m (10 ft. 7 in.) | 3.21 m (10 ft. 7 in.) |
| B Hood Height | 2.26 m (7 ft. 5 in.) | 2.26 m (7 ft. 5 in.) | 2.38 m (7 ft. 10 in.) | 2.38 m (7 ft. 10 in.) | 2.38 m (7 ft. 10 in.) | 2.38 m (7 ft. 10 in.) |
| C Ground Clearance | 349 mm (13.75 in.) | 349 mm (13.75 in.) | 430 mm (17 in.) | 430 mm (17 in.) | 430 mm (17 in.) | 430 mm (17 in.) |
| D Length From Centerline to Front Axle | 1.37 m (4 ft. 6 in.) | 1.37 m (4 ft. 6 in.) | 1.37 m (4 ft. 6 in.) | 1.37 m (4 ft. 6 in.) | 1.37 m (4 ft. 6 in.) | 1.37 m (4 ft. 6 in.) |
| E Wheelbase | 2.76 m (9 ft. 6 in.) | 2.76 m (9 ft. 6 in.) | 2.76 m (9 ft. 6 in.) | 2.76 m (9 ft. 6 in.) | 2.76 m (9 ft. 6 in.) | 2.76 m (9 ft. 6 in.) |
| F Overall Length, Bucket on Ground | 6.91 m (22 ft. 8 in.) | 7.19 m (23 ft. 7 in.) | 7.20 m (23 ft. 8 in.) | 7.26 m (23 ft. 10 in.) | 7.64 m (25 ft. 1 in.) | 7.70 m (25 ft. 4 in.) |
| G Height to Hinge Pin, Fully Raised | 3.58 m (11 ft. 9 in.) | 3.58 m (11 ft. 9 in.) | 3.66 m (12 ft. 1 in.) | 3.66 m (12 ft. 1 in.) | 4.11 m (13 ft. 6 in.) | 4.11 m (13 ft. 6 in.) |
| H Dump Clearance, 45 deg., Full Height | 2.52 m (8 ft. 3 in.) | 2.52 m (8 ft. 3 in.) | 2.60 m (8 ft. 7 in.) | 2.56 m (8 ft. 5 in.) | 3.08 m (10 ft. 2 in.) | 3.04 m (10 ft. 0 in.) |
| I Reach, 45-deg. Dump, Full Height | 1.15 m (3 ft. 9 in.) | 1.15 m (3 ft. 9 in.) | 1.08 m (3 ft. 7 in.) | 1.12 m (3 ft. 9 in.) | 1.13 m (3 ft. 9 in.) | 1.17 m (3 ft. 11 in.) |
| J Reach, 45-deg. Dump, 2.13-m (7 ft. 0 in.) Clearance | 1.47 m (4 ft. 10 in.) | 1.47 m (4 ft. 10 in.) | 1.45 m (4 ft. 10 in.) | 1.46 m (4 ft. 10 in.) | 1.85 m (6 ft. 1 in.) | 1.86 m (6 ft. 2 in.) |
| K Maximum Digging Depth | 174 mm (6.8 in.) | 174 mm (6.8 in.) | 90 mm (4 in.) | 100 mm (4 in.) | 90 mm (4 in.) | 100 mm (4 in.) |
| L Maximum Rollback at Ground Level | 41 deg. | 41 deg. | 41 deg. | 41 deg. | 40 deg. | 41 deg. |
| M Maximum Rollback, Boom Fully Raised | 55 deg. | 55 deg. | 55 deg. | 55 deg. | 49 deg. | 55 deg. |
| N Maximum Bucket Dump Angle, Fully Raised | 50 deg. | 50 deg. | 50 deg. | 50 deg. | 44 deg. | 44 deg. |
| Loader Clearance Circle, Bucket Carry Position | 11.19 m (36 ft. 8 in.) | 11.19 m (36 ft. 8 in.) | 11.15 m (36 ft. 7 in.) | 11.16 m (36 ft. 8 in.) | 11.53 m (37 ft. 10 in.) | 11.54 m (37 ft. 11 in.) |
| Specifications With Bucket With Bolt-On Edge | | | | | | |
| Capacity, Heaped | 1.9 m ³ (2.5 cu. yd.) | 1.9 m ³ (2.5 cu. yd.) | 1.9 m ³ (2.5 cu. yd.) | 2.1 m ³ (2.75 cu. yd.) | 1.9 m ³ (2.5 cu. yd.) | 2.1 m ³ (2.75 cu. yd.) |
| Capacity, Struck | 1.6 m ³ (2.1 cu. yd.) | 1.6 m ³ (2.1 cu. yd.) | 1.6 m ³ (2.0 cu. yd.) | 1.9 m ³ (2.5 cu. yd.) | 1.6 m ³ (2.0 cu. yd.) | 1.9 m ³ (2.5 cu. yd.) |
| Bucket Weight With Bolt-On Cutting Edge | 1230 kg (2,708 lb.) | 1230 kg (2,708 lb.) | 1230 kg (2,708 lb.) | 1307 kg (2,882 lb.) | 1230 kg (2,708 lb.) | 1307 kg (2,882 lb.) |
| Bucket Width | 2.52 m (8 ft. 3 in.) | 2.52 m (8 ft. 3 in.) | 2.52 m (8 ft. 4 in.) | 2.52 m (8 ft. 4 in.) | 2.52 m (8 ft. 4 in.) | 2.52 m (8 ft. 4 in.) |
| Breakout Force | 6700 kg (14,753 lb.) | 6700 kg (14,753 lb.) | 6711 kg (14,795 lb.) | 6343 kg (13,983 lb.) | 6074 kg (13,390 lb.) | 5736 kg (12,645 lb.) |
| Tipping Load, Straight, No Tire Deflection | 6726 kg (14,811 lb.) | 8591 kg (18,917 lb.) | 8705 kg (19,191 lb.) | 8615 kg (18,992 lb.) | 7061 kg (15,566 lb.) | 6973 kg (15,372 lb.) |
| Tipping Load, Straight, With Tire Deflection | 6363 kg (14,011 lb.) | 8109 kg (17,856 lb.) | 8274 kg (18,241 lb.) | 8178 kg (18,029 lb.) | 6747 kg (14,874 lb.) | 6657 kg (14,676 lb.) |
| Tipping Load, 40-deg. Full Turn, No Tire Deflection | 5833 kg (12,844 lb.) | 7395 kg (16,284 lb.) | 7516 kg (16,569 lb.) | 7427 kg (16,373 lb.) | 6061 kg (13,362 lb.) | 5972 kg (13,165 lb.) |
| Tipping Load, 40-deg. Full Turn, With Tire Deflection | 5385 kg (11,858 lb.) | 6789 kg (14,949 lb.) | 6981 kg (15,390 lb.) | 6885 kg (15,178 lb.) | 6369 kg (14,041 lb.) | 5571 kg (12,281 lb.) |
| Rated Operating Load, 50% Full-Turn Tipping Load, No Tire Deflection (conforms to ISO 14397-1)* | 2917 kg (6,422 lb.) | 3698 kg (8,142 lb.) | 3758 kg (8,284 lb.) | 3713 kg (8,186 lb.) | 3030 kg (6,681 lb.) | 2986 kg (6,582 lb.) |
| Rated Operating Load, 50% Full-Turn Tipping Load, With Tire Deflection (conforms to ISO 14397-1)* | 2693 kg (5,929 lb.) | 3395 kg (7,475 lb.) | 3490 kg (7,695 lb.) | 3442 kg (7,589 lb.) | 3184 kg (7,020 lb.) | 2785 kg (6,140 lb.) |
| Operating Weight | 10 419 kg (22,943 lb.) | 11 273 kg (24,823 lb.) | 11 683 kg (25,756 lb.) | 11 760 kg (25,926 lb.) | 11 864 kg (26,155 lb.) | 11 941 kg (26,325 lb.) |
| <i>Loader operating information is based on machine with identified linkage and standard equipment, John Deere PowerTech E 4045H/PowerTech PSS 4045 engine, ROPS cab, transmission side-frame guards, standard tires (17.5 R 25 for Tier 3/20.5 R 25 for FT4), full fuel tank, and 79-kg (175 lb.) operator. This information is affected by changes in tires, ballast, and different attachments.</i> | | | | | | |
| <i>*Rated operating capacity based on Deere attachments only.</i> | | | | | | |

Dimensions and Specifications With Hi-Vis Coupler and Construction Forks **444 G Z-BAR / HIGH-LIFT TIER 3 / FT4**

444 G-TIER Z-BAR / HIGH-LIFT LOADER WITH HI-VIS COUPLER AND HOOK-ON CONSTRUCTION FORKS

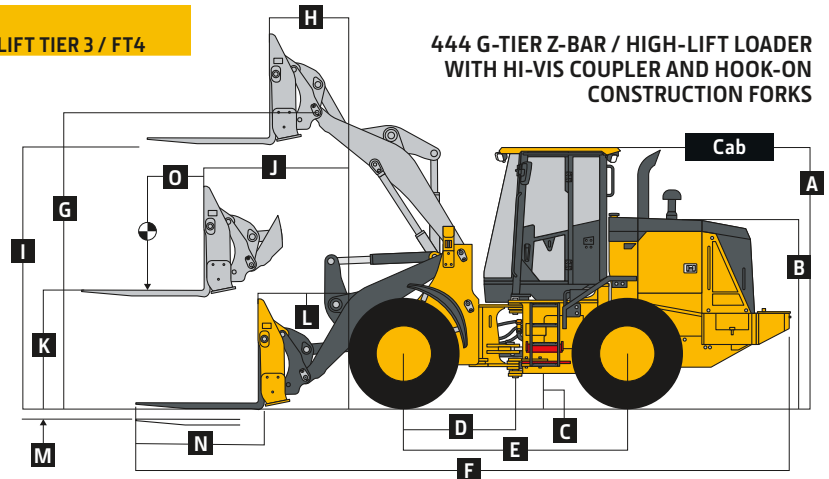

| | <i>Tier 3</i> | <i>Tier 3</i> | <i>FT4</i> | <i>FT4</i> |
|--|------------------------------------|--|------------------------------------|------------------------------------|
| | <i>Z-Bar</i> | <i>Z-Bar (with concrete counterweight)</i> | <i>Z-Bar</i> | <i>Z-Bar / High-Lift</i> |
| Dimensions With Forks | <i>1.52-m (60 in.) tine length</i> | <i>1.52-m (60 in.) tine length</i> | <i>1.52-m (60 in.) tine length</i> | <i>1.52-m (60 in.) tine length</i> |
| A Height to Top of Cab | 3.13 m (10 ft. 3 in.) | 3.13 m (10 ft. 3 in.) | 3.21 m (10 ft. 7 in.) | 3.13 m (10 ft. 3 in.) |
| B Hood Height | 2.26 m (7 ft. 5 in.) | 2.26 m (7 ft. 5 in.) | 2.38 m (7 ft. 10 in.) | 2.30 m (7 ft. 5 in.) |
| C Ground Clearance | 349 mm (13.75 in.) | 349 mm (13.75 in.) | 430 mm (17 in.) | 349 mm (13.75 in.) |
| D Length From Centerline to Front Axle | 1.37 m (4 ft. 6 in.) | 1.37 m (4 ft. 6 in.) | 1.37 m (4 ft. 6 in.) | 1.37 m (4 ft. 6 in.) |
| E Wheelbase | 2.76 m (9 ft. 6 in.) | 2.76 m (9 ft. 6 in.) | 2.76 m (9 ft. 6 in.) | 2.76 m (9 ft. 6 in.) |
| F Overall Length, Forks on Ground | 7.68 m (25 ft. 2 in.) | 7.96 m (26 ft. 2 in.) | 7.96 m (26 ft. 2 in.) | 8.50 m (27 ft. 11 in.) |
| G Height to Hinge Pin, Fully Raised | 3.58 m (11 ft. 9 in.) | 3.58 m (11 ft. 9 in.) | 3.66 m (12 ft. 1 in.) | 4.11 m (13 ft. 6 in.) |
| H Reach, Fully Raised | 0.93 m (3 ft. 1 in.) | 0.93 m (3 ft. 1 in.) | 0.93 m (3 ft. 1 in.) | 0.94 m (3 ft. 2 in.) |
| I Fork Height, Fully Raised | 3.38 m (11 ft. 1 in.) | 3.38 m (11 ft. 1 in.) | 3.38 m (11 ft. 1 in.) | 3.79 m (12 ft. 5 in.) |
| J Maximum Reach, Fork Level | 1.64 m (5 ft. 4 in.) | 1.64 m (5 ft. 4 in.) | 1.64 m (5 ft. 4 in.) | 1.84 m (6 ft. 0 in.) |
| K Fork Height, Maximum Reach | 1.64 m (5 ft. 5 in.) | 1.64 m (5 ft. 5 in.) | 1.64 m (5 ft. 5 in.) | 1.70 m (5 ft. 7 in.) |
| L Reach, Ground Level | 1.10 m (3 ft. 8 in.) | 1.10 m (3 ft. 8 in.) | 1.10 m (3 ft. 8 in.) | 1.31 m (4 ft. 4 in.) |
| M Depth Below Ground | 194 mm (7.6 in.) | 194 mm (7.6 in.) | 194 mm (7.6 in.) | 16 mm (0.6 in.) |
| N Tine Length | 1.52 m (60 in.) | 1.52 m (60 in.) | 1.52 m (60 in.) | 1.52 m (60 in.) |
| O Load Position, 50% Tine Length | 0.76 m (30 in.) | 0.76 m (30 in.) | 0.76 m (30 in.) | 0.76 m (30 in.) |
| Specifications With Forks | | | | |
| Tipping Load, Straight, No Tire Deflection | 4366 kg (9,614 lb.) | 5616 kg (12,367 lb.) | 5692 kg (12,548 lb.) | 4918 kg (10,842 lb.) |
| Tipping Load, Straight, With Tire Deflection | 4233 kg (9,321 lb.) | 5451 kg (12,003 lb.) | 4895 kg (10,791 lb.) | 4203 kg (9,266 lb.) |
| Tipping Load, 40-deg. Full Turn, No Tire Deflection | 3767 kg (8,296 lb.) | 4814 kg (10,602 lb.) | 5685 kg (12,533 lb.) | 4911 kg (10,826 lb.) |
| Tipping Load, 40-deg. Full Turn, With Tire Deflection | 3594 kg (7914 lb.) | 4605 kg (10,140 lb.) | 4890 kg (10,780 lb.) | 4197 kg (9,252 lb.) |
| Rated Operating Load, 50% Full-Turn Tipping Load, With Tire Deflection (conforms to ISO 14397-1 and SAE J1197)* | 1797 kg (3,957 lb.) | 2303 kg (5,071 lb.) | 2445 kg (5,390 lb.) | 2098 kg (4,626 lb.) |
| Rated Operating Load, Rough Terrain, 60% Full-Turn Tipping Load, With Tire Deflection (conforms to EN474-3)* | 2156 kg (4,748 lb.) | 2763 kg (6,084 lb.) | 2934 kg (6,468 lb.) | 2518 kg (5,551 lb.) |
| Rated Operating Load, Firm and Level Ground, 80% Full-Turn Tipping Load, With Tire Deflection (conforms to EN474-3)* | 2875 kg (6,331 lb.) | 3684 kg (8,112 lb.) | 3912 kg (8,624 lb.) | 3357 kg (7,402 lb.) |
| Operating Weight | 10,450 kg (23,011 lb.) | 11 304 kg (24,892 lb.) | 11 713 kg (25,822 lb.) | 11 894 kg (26,221 lb.) |
| <i>Loader operating information is based on machine with identified linkage and standard equipment, John Deere PowerTech E 4045H/PowerTech PSS 4045 engine, ROPS cab, transmission side-frame guards, standard tires (17.5 R25 for Tier 3/20.5 R25 for FT4), full fuel tank, and 79-kg (175 lb.) operator. This information is affected by changes in tires, ballast, and different attachments.</i> | | | | |
| <i>*Rated operating capacity based on Deere attachments only.</i> | | | | |

444 G-TIER

While general information, pictures, and descriptions are provided, some illustrations and text may include product options and accessories NOT AVAILABLE in all regions, and in some countries products and accessories may require modifications or additions to ensure compliance with the local regulations of those countries.

444 G Z-BAR / HIGH-LIFT TIER 3 Adjustments to Operating Weights and Tipping Loads With Buckets

Adjustments to operating weights, tipping loads, and tires are based on Z-Bar machine with pin-on 1.9-m³ (2.5 cu. yd.) general-purpose bucket with bolt-on cutting edge, ROPS cab, rear cast bumper/counterweight, transmission side-frame guards, bottom guards, standard tires, full fuel tank, and 79-kg (175 lb.) operator*

| Add (+) or deduct (-) kg (lb.) as indicated | Operating Weight | Tipping Load, | | Tread Width | Width Over Tires | Vertical Height |
|---|--------------------|--------------------|--------------------|-------------------|--------------------|--------------------|
| | | Straight | 40-deg. Full Turn | | | |
| for loaders with 1-piece rims | 0 kg (0 lb.) | 0 kg (0 lb.) | 0 kg (0 lb.) | 0 mm (0 in.) | 0 mm (0 in.) | 0 mm (0 in.) |
| Titan 17.5-25 12 PR L2 (with 3-piece rims) | -140 kg (-308 lb.) | -100 kg (-220 lb.) | -88 kg (-194 lb.) | 0 mm (0 in.) | 0 mm (0 in.) | 0 mm (0 in.) |
| Titan 17.5-25 16 PR L2 | -8 kg (-18 lb.) | -6 kg (-13 lb.) | -5 kg (-11 lb.) | 0 mm (0 in.) | +19 mm (+0.75 in.) | +11 mm (+0.4 in.) |
| Firestone 17.5-25 16 PR L3 (with 3-piece rims) | +352 kg (+775 lb.) | +251 kg (+553 lb.) | +222 kg (+489 lb.) | +50 mm (+2.0 in.) | +144 mm (+5.7 in.) | +80 mm (+3.15 in.) |
| Michelin 20.5 R 25 L2 1-Star XTLA ⁶ | +212 kg (+467 lb.) | +151 kg (+333 lb.) | +133 kg (+293 lb.) | +50 mm (+2.0 in.) | +144 mm (+5.7 in.) | +64 mm (+2.5 in.) |
| Firestone 20.5-25 L3 16 PR Bias ⁶ | +248 kg (+546 lb.) | +177 kg (+390 lb.) | +156 kg (+344 lb.) | +50 mm (+1.9 in.) | +144 mm (+5.7 in.) | +41 mm (+1.5 in.) |
| Titan 20.5-25 L3 16 PR ⁶ | +116 kg (+255 lb.) | +83 kg (+183 lb.) | +73 kg (+161 lb.) | 0 mm (0 in.) | +7 mm (+0.3 in.) | +19 mm (+0.75 in.) |
| Titan 17.5 R 25 L2 1-Star General Purpose | +62 kg (+137 lb.) | +44 kg (+97 lb.) | +39 kg (+86 lb.) | 0 mm (0 in.) | +21 mm (+0.8 in.) | +7 mm (+0.3 in.) |
| Michelin 17.5 R 25 L2 1-Star General Purpose | +114 kg (+251 lb.) | +81 kg (+178 lb.) | +72 kg (+159 lb.) | 0 mm (0 in.) | +1 mm (±0.04 in.) | +19 mm (+0.75 in.) |
| Bridgestone 17.5 R 25 L2 1-Star General Purpose | +31 kg (+68 lb.) | +71 kg (+156 lb.) | +60 kg (+132 lb.) | 0 mm (0 in.) | 0 mm (0 in.) | 0 mm (0 in.) |
| Hydraulic Fan Drive | | | | | | |

*May change based on vehicle configuration, weight, or tire-pressure adjustments.

⁶Requires 8-deg. rear axle stops.

444 G Z-BAR / HIGH-LIFT FINAL TIER 4 (FT4) Adjustments to Operating Weights and Tipping Loads With Buckets

Adjustments to operating weights, tipping loads, and tires are based on Z-Bar machine with pin-on 1.9-m³ (2.5 cu. yd.) general-purpose bucket with bolt-on cutting edge, ROPS cab, rear cast bumper/counterweight, transmission side-frame guards, bottom guards, standard tires, full fuel tank, and 79-kg (175 lb.) operator*

| Add (+) or deduct (-) kg (lb.) as indicated | Operating Weight | Tipping Load, | | Tread Width | Width Over Tires | Vertical Height |
|---|--------------------|--------------------|--------------------|--------------------|------------------|-------------------|
| | | Straight | 40-deg. Full Turn | | | |
| for loaders with 1-piece rims | 0 kg (0 lb.) | 0 kg (0 lb.) | 0 kg (0 lb.) | 0 mm (0 in.) | 0 mm (0 in.) | 0 mm (0 in.) |
| Michelin 20.5 R 25 L2 1-Star XTLA ⁶ | -236 kg (-520 lb.) | -168 kg (-368 lb.) | -149 kg (-326 lb.) | -0.05 m (-1.1 in.) | -0.14 m (-7 in.) | -0.06 m (-10 in.) |
| Titan 17.5 R 25 L2 1-Star General Purpose | -229 kg (-504 lb.) | -163 kg (-358 lb.) | -144 kg (-316 lb.) | -0.05 m (-1.1 in.) | -0.12 m (-8 in.) | -0.10 m (-9 in.) |
| Michelin 17.5 R 25 L2 1-Star XHA2 | -156 kg (-343 lb.) | -111 kg (-243 lb.) | -98 kg (-214 lb.) | 0 mm (0 in.) | -30 mm (-2 in.) | 0 mm (0 in.) |
| Advance 20.5 R 25 L3 1-Star Radial (with 3-piece rims) ⁶ | -112 kg (-246 lb.) | -80 kg (-176 lb.) | -70 kg (-154 lb.) | -0.05 m (-1.1 in.) | -0.10 m (-9 in.) | -0.07 m (-10 in.) |
| Advance GLR09-M3 17.5 R 25 L2 2-Star Radial (with 3-piece rims) | -92 kg (-202 lb.) | -66 kg (-143 lb.) | -58 kg (-126 lb.) | -0.05 m (-1.1 in.) | -0.10 m (-9 in.) | -0.09 m (-9 in.) |
| MAXAM MS301 17.5 R 25 L3 2-Star Radial (with 3-piece rims) | -228 kg (-502 lb.) | -163 kg (-358 lb.) | -144 kg (-316 lb.) | -0.05 m (-1.1 in.) | -0.10 m (-9 in.) | -0.02 m (-12 in.) |
| MAXAM 20.5 R 25 L3 2-Star Radial (with 3-piece rims) ⁶ | | | | | | |

*May change based on vehicle configuration, weight, or tire-pressure adjustments.

⁶Requires 8-deg. rear axle stops.

Additional equipment

Key: ● Standard ▲ Optional or special
See your John Deere dealer for further information.

444 G Engine

- Wet-sleeve cylinder liners
- Programmable auto-idle and auto shutdown
- Starter excessive-cranking protection
- Automatic engine cool-down timer
- Automatic derating for exceeded system temperatures
- Serpentine drive belt for automatic tensioner
- Electrical fuel-priming pump
- Dual-stage fuel filter and water separator
- 500-hour vertical spin-on oil filter
- Automatic glow plugs for cold start (EPA Final Tier 4 [FT4]/EU Stage V only)
- ▲ Engine-block heater (recommended for cold starts below -23 deg. C [-10 deg. F])
- ▲ Centrifugal engine air pre-cleaner

Powertrain

- Clutch cutoff with 3 operator settings: Level ground, small slope, or steep slope
- Clutch calibration engaged from monitor
- 2,000-hour vertical spin-on transmission filter
- Transmission fill tube and sight gauge
- 4-speed transmission with non-lockup torque converter
- Limited-slip differential

Cooling System

- Engine radiator
- Engine oil cooler
- Hydraulic oil cooler (oil to air)
- Transmission oil cooler (oil to air)
- Charge air cooler (air to air)
- Coolant recovery tank
- Antifreeze, -47 deg. C (-52 deg. F)
- Cool-on-demand, hydraulically driven fan (standard for EPA FT4/EU Stage V; optional for EPA Tier 3/EU Stage IIIA)
- Enclosed fan safety guard
- ▲ Automatic reversing fan drive

Hydraulics

- Pilot hydraulic controls
- Automatic return-to-dig bucket positioner
- In-cab adjustable automatic boom-height kickout/return to carry
- Reservoir with sight gauge and fill strainer
- Hydraulic diagnostic ports
- 4,000-hour in-tank filter
- 2 function — joystick with F-N-R
- ▲ 3 function — joystick with F-N-R and 3rd-function auxiliary lever
- ▲ Ride control, automatic with monitor-adjustable speed settings
- ▲ Hydraulic control system for quick-coupler locking pins

444 G Hydraulics (continued)

- ▲ Hydrau™ XR cold-temperature hydraulic fluid recommended below -25 deg. C (-13 deg. F)

Steering Systems

- Conventional steering wheel with spinner knob
- ▲ Secondary steering

Electrical

- Solid-state electrical power-distribution system
- Lockable master electrical-disconnect switch
- Battery-terminal safety covers
- Pre-wired for beacon/strobe light
- ▲ Rotary beacon
- Lights: Halogen driving lights (2) / Front (2) and rear cab (2) / Halogen front turn signals and flashers / LED stop- and taillights
- Horn, electric
- Reverse warning alarm
- Multifunction/multi-language 127-mm (5 in.) LCD color monitor includes: Digital instruments — Analog display (engine coolant temperature and transmission oil temperature) / Digital display (engine rpm, transmission gear/direction indicator, hour meter, fuel level, diesel exhaust fluid (DEF) level, speedometer, and average fuel consumption)
- Indicator lights: Standard and selected options / Amber caution and red stop
- Operator-warning messages
- Built-in diagnostics: Diagnostic-code details / Sensor values / Calibrations / Individual circuit tester
- Radio ready
- ▲ AM/FM radio
- 24- to 12-volt, 15-amp converter and cab power port

Operator's Station

- Cab with air conditioning/heater (ROPS/FOPS Level 2, isolation mounted)
- Keyless start with multiple security modes
- Sealed-switch module with function indicators
- Seat with headrest, fabric cover, and adjustable mechanical suspension
- ▲ Seat with headrest, fabric cover, and adjustable air suspension
- High-visibility, bright-orange seat belt, 76 mm (3 in.), with retractor
- Cup holder
- Coat hook
- Dome and reading light
- Rubber floor mat
- Tilt steering column

444 G Operator's Station (continued)

- Operator's manual storage compartment
- Outside (2) and inside (1) rearview mirrors
- Left-side operator-station access
- Slip-resistant steps and ergonomic handholds
- Pull-down front sun visor
- Front and rear intermittent windshield wipers and washers
- Rearview camera (standard for EPA FT4/EU Stage V; optional for EPA Tier 3/EU Stage IIIA)
- ▲ Fire extinguisher bracket

Loader Linkage

- Z-Bar loader linkage
- ▲ High-lift linkage

Buckets and Attachments

- ▲ Full line of Deere pin-on buckets, coupler buckets, and forks
- ▲ Hi-Vis hydraulic coupler that accepts Euro-pattern attachments (ISO)
- ▲ Full line of Deere hook-on buckets and forks
- ▲ John Deere hydraulic coupler that accepts JRB-pattern attachments

Overall Vehicle

- JDLink™ wireless communication system (available in specific countries; see your dealer for details)
- Front and rear tie-downs
- Rear counterweight with hitch and locking pin (standard for EPA FT4/EU Stage V; optional for EPA Tier 3/EU Stage IIIA)
- Articulation locking bar
- Loader boom service locking bar
- 40-deg. steering articulation to each side with rubber-cushion stops on frame
- Vandal protection with lockable engine enclosures, counterweight compartments, and filler access for radiator/fuel/DEF/hydraulic transmission
- Left-side service steps and handholds
- Fuel-tank fill strainer
- Ground-level fuel and DEF fill
- Same-side ground-level daily servicing
- 20.5R25 radial tires on 3-piece rims (standard for EPA FT4/EU Stage V; optional for EPA Tier 3/EU Stage IIIA)
- ▲ 20.5R25 bias tires on 3-piece rims
- ▲ 20.5R25 radial snow tires on 3-piece rims
- Fenders, front narrow
- ▲ Transmission side-frame and bottom guards
- ▲ Lift eyes
- ▲ License-plate bracket and light

While general information, pictures, and descriptions are provided, some illustrations and text may include product options and accessories NOT AVAILABLE in all regions, and in some countries products and accessories may require modifications or additions to ensure compliance with the local regulations of those countries.

Net engine power is with standard equipment including air cleaner, exhaust system, alternator, and cooling fan at test conditions per ISO 9249. No derating is required up to 3050-m (10,000 ft.) altitude. Specifications and design subject to change without notice. Specifications with the exception of bucket capacity are in accordance with all applicable ISO standards. Except where otherwise noted, these specifications are based on a unit with applicable linkage and standard equipment, ROPS cab, rear cast bumper/counterweight, transmission side-frame guards, bottom guards, standard tires, full fuel tank, and 79-kg (175 lb.) operator.



MW444GAB (23-12)



JOHN DEERE